



Rexello[®]

The Name That Carries Weight

ISO 9001-2000
Quality System
Quality Endorsed
Company
Certification
No. QFC13252



FORGED STEEL **HSC SERIES** INDUSTRIAL CASTORS



HSC SERIES

SWIVEL / RIGID CASTORS

HSC/F SERIES

RIGID CASTORS

This range of robust single and Twin Wheel castors is the most comprehensive of its style. The swivel has a heavy duty forged steel top plate which joins the outer swivel ring by a full complement ball race (Rexello unique side race). The race serves both as thrust and radial bearing and is provided with a Nylon seal* at the top and greased through a hydraulic nipple. This construction prevents downward escape of the lubricant and creates a complete grease reservoir. The press formed heavy duty cylindrical shaped side plates are continuously welded to the swivel ring to form the fork and give the best strength to weight ratio.

*(Steel seal available for Higher Temperature)

PT 14
ALTERNATIVE PLATE
ALSO AVAILABLE

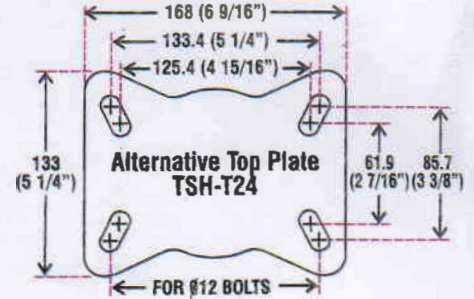

STANDARD PLATE FOR
HSC SERIES-PT 11
for Details Refer On Page 03



Swivel Castor

Rigid (Fixed) Castor

Swivel Castor Codes & Load Capacities.

Example: **HSC2/PT11/RT/150** ← Code of Castor with Plain bearing wheel
Load Capacity under Ideal & Average Conditions → **280/225 kgs**
Example: **HSC2/PT11/RT/150/R** ← Code of Castor with Roller Bearing wheel swivel

Rigid (Fixed) Castor Codes & Load Capacities.

Example: **HSC2/F/RT/150** ← Code of Castor with Plain bearing wheel
Load Capacity under Ideal & Average Conditions. → **280/225 kgs**
Example: **HSC2/F/RT/150/R** ← Code of Castor with Roller Bearing wheel swivel



HSC SERIES

WHEELS & BEARINGS

ISO 9001-2000
Quality System
Quality Endorsed Company
Certification No: QEC13252

CHOICE OF WHEELS AVAILABLE



RT
RUBBER TYREO
CAST IRON WHEEL



RPX

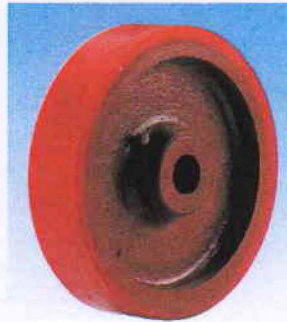

RPU
POLYURETHANE TYREO
CAST IRON WHEEL



N
NYLON WHEEL



NT
NYLON BONDED
CAST IRON WHEEL



P
REINFORCED PHENOREX
FIBRE WHEEL



PT
PHENOREX FIBRE TYREO
CAST IRON WHEEL



UHM
ULTRA HIGH MOLECULAR
POLYMER WHEEL



WHM
WHITE VIRGIN QUALITY
ULTRA HIGH MOLECULAR
POLYMER WHEEL



C
Castor with
CAST IRON WHEEL



PUN
POLYURETHANE MOULDED
ON NYLON CENTRE WHEEL

Note :

1. All steel wheel can also be incorporated in this series.
2. Ball Bearing & Taper Roller Bearing in the wheel can also be incorporated.
3. Wheel Brakes available in Swivel & Rigid castors, add Bk to code.
4. Directional lock can be incorporated in the Swivel castors, add SL to code.
5. Wheel Diameter above 12" also available.

BEARINGS AVAILABLE



TAPER ROLLER BEARING



BALL BEARING / Z



NY ROLLER BEARING WITH SLEEVE



STEEL ROLLER BEARING



HSC SERIES

SWIVEL CASTORS



STANDARD PLATE FOR SWIVEL CASTORS

Top Plate Size D X E mm (Inches)	Bolt Hole Centres F2 X G2 F1 X G1 mm (Inches)	Hole Dia H mm (Inches)
150 X 110 (6 X 4 ⁵ / ₁₆)	120 X 60 (4 ²³ / ₃₂ X 2 ³ / ₈) 105 X 80 (4 ¹ / ₈ X 2 ⁵ / ₈)	25 X 13 (1 X ¹ / ₂)

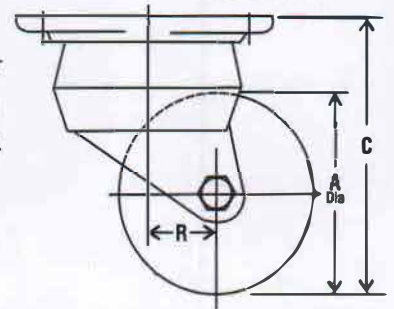
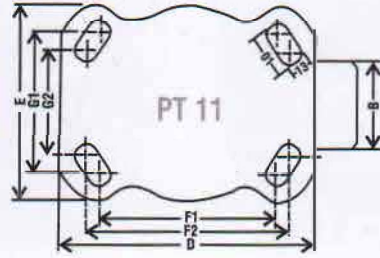

DATA FOR SWIVEL CASTORS

WHEEL DIA A mm (Inches)	TREAD WIDTH B mm (Inches)	Overall Height C mm (Inches)	Offset R mm (Inches)	Castor with RUBBER TYRED CAST IRON WHEEL RT	Castor with RPU	Castor with NYLON WHEEL N	Castor with NT
100 (4)	50 (2)	152 (6)	35 (1.365)	HSC2/PT11/RT/100 225/180 kgs HSC2/F/RT/100	HSC2/PT11/RPU/100 330/180 kgs HSC2/F/RPU/100	HSC2/PT11/N/100 280/450 kgs HSC2/F/N/100 225	HSC2/PT11/NT/100 250/200 kgs HSC2/F/NT/100
125 (5)	50 (2)	178 (7)	39 (1.520)	HSC2/PT11/RT/125 230/200 kgs HSC2/F/RT/125	HSC2/PT11/RPU/125 400/350 kgs HSC2/F/RPU/125	HSC2/PT11/N/125 300/300	HSC2/PT11/NT/125 275/225 kgs HSC2/F/NT/125
150 (6)	50 (2)	203 (8)	44 (1.745)	HSC2/PT11/RT/150 280/225 kgs HSC2/F/RT/150	HSC2/PT11/RPU/150 500/450 kgs HSC2/F/RPU/150	HSC2/PT11/N/150 400/380 kgs HSC2/F/N/150	HSC2/PT11/NT/150 450/400 kgs HSC2/F/NT/150
200 (8)	50 (2)	254 (10)	70 (2.756)	HSC2/PT11/RT/200 500/450 kgs HSC2/F/RT/200	HSC2/PT11/RPU/200 900/850 kgs HSC2/F/RPU/200	HSC2/PT11/N/200 500/480 kgs HSC2/F/N/200	HSC2/PT11/NT/200 550/500 kgs HSC2/F/NT/200
250 (10)	50 (2)	305 (12)	75 (2.953)	HSC2/PT11/RT/250 650/600 kgs HSC2/F/RT/250	HSC2/PT11/RPU/250 1050/1000 kgs HSC2/F/RPU/250		
300 (12)	50 (2)	356 (14)	80 (3.149)	HSC2/PT11/RT/300 700/600 kgs HSC2/F/RT/300	HSC2/PT11/RPU/300 1200/1150 kgs HSC2/F/RPU/300		
150 (6)	75 (3)	210 (8 ¹ / ₄)	44 (1.745)	HSC3/PT11/RT/150 420/350 kgs HSC3/F/RT/150	HSC3/PT11/RPU/150 650/600 kgs HSC2/F/RPU/150		HSC3/PT11/NT/150 500/450 kgs HSC3/F/NT/150
200 (8)	75 (3)	260 (10 ¹ / ₄)	70 (2.756)	HSC3/PT11/RT/200 750/650 kgs HSC3/F/RT/200	HSC3/PT11/RPU/200 1150/1100 kgs HSC2/F/RPU/200		HSC3/PT11/NT/200 600/550 kgs HSC3/F/NT/200
250 (10)	75 (3)	311 (12 ¹ / ₄)	75 (2.953)	HSC3/PT11/RT/250 825/700 kgs HSC3/F/RT/250	HSC3/PT11/RPU/250 1200/1150 kgs HSC2/F/RPU/250		
300 (12)	75 (3)	362 (14 ¹ / ₄)	80 (3.149)	HSC3/PT11/RT/300 875/750 kgs HSC3/F/RT/300	HSC3/PT11/RPU/300 1350/1300 kgs HSC2/F/RPU/300		

Note : Tolerance on the wheel diameter 'D' upto & including 100 mm shall be ± 2 mm and for the diameters greater than 100 mm shall be ± 2 percent (%)



ISO 9001-2000
Quality System
Quality Endorsed Company
Certification No. QEC13252

HSC/F SERIES

RIGID CASTORS

ISO 9001-2000
Quality System
Quality Endorsed Company
Certification No. QEC13252



STANDARD PLATE FOR RIGID / FIXED CASTORS

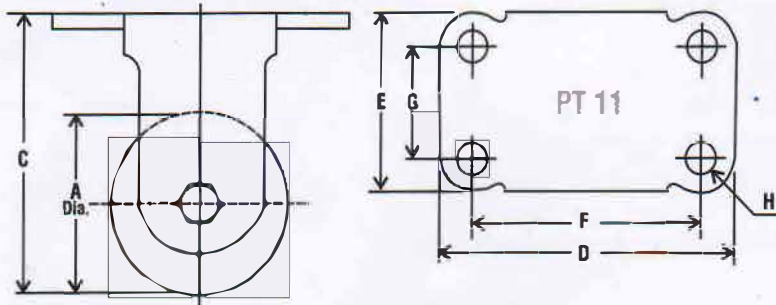

Top Plate Size for Tread Width 60mm (2") D X E mm (Inches)	Top Plate Size for Tread Width 75mm (3") D X E mm (Inches)	Bolt Hole Centres F X G mm (Inches)	Bolt Dia H mm (Inches)
155.6 X 92.1 (6 1/8 X 3 5/8)	158.8 X 108 (6 1/4 X 4 1/4)	120.5 X 59.0 (4 3/4 X 2 3/16)	13.5 17/32

Castor with TEXTILE REINFORCED PHENOREX WHEEL P	Castor with PT	Castor with UHM/WHM	Castor with CAST IRON WHEEL C	DATA FOR RIGID CASTORS		
				Overall Height C mm (Inches)	TREAD WIDTH B mm (Inches)	WHEEL DIA A mm (Inches)
HSC2/PT11/P/100 300/250 kgs HSC2/F/P/100	HSC2/PT11/PT/100 350/300 kgs HSC2/F/PT/100	HSC2/PT11/UHM/100 250/220 kgs HSC2/F/UHM/100	HSC2/PT11/C/100 250/200 kgs HSC2/F/C/100	152 (6)	50 (2)	100 (4)
HSC2/PT11/P/125 350/300 kgs HSC2/F/P/125	HSC2/PT11/PT/125 375/350 kgs HSC2/F/PT/125	HSC2/PT11/UHM/125 350/300 kgs HSC2/F/UHM/125	HSC2/PT11/C/125 400/480 kgs HSC2/F/C/125	178 (7)	50 (2)	125 (5)
HSC2/PT11/P/150 500/400 kgs HSC2/F/P/150	HSC2/PT11/PT/150 550/500 kgs HSC2/F/PT/150	HSC2/PT11/UHM/150 525/475 kgs HSC2/F/UHM/150	HSC2/PT11/C/150 800/480 kgs HSC2/F/C/150	204 (8)	50 (2)	150 (6)
HSC2/PT11/P/200 720/540 kgs HSC2/F/P/200	HSC2/PT11/PT/200 750/700 kgs HSC2/F/PT/200	HSC2/PT11/UHM/200 700/650 kgs HSC2/F/UHM/200	HSC2/PT11/C/200 1000/900 kgs HSC2/F/C/200	254 (10)	50 (2)	200 (8)
HSC2/PT11/P/250 820/650 kgs HSC2/F/P/250	HSC2/PT11/PT/250 850/800 kgs HSC2/F/PT/250	HSC2/PT11/UHM/250 800/750 kgs HSC2/F/UHM/250	HSC2/PT11/C/250 1150/1000 kgs HSC2/F/C/250	305 (12)	50 (2)	250 (10)
HSC2/PT11/P/300 950/800 kgs HSC2/F/P/300	HSC2/PT11/PT/300 975/925 kgs HSC2/F/PT/300	HSC2/PT11/UHM/300 900/850 kgs HSC2/F/UHM/300	HSC2/PT11/C/300 1225/1100 kgs HSC2/F/C/300	356 (14)	50 (2)	300 (12)
HSC3/PT11/P/150 650/500 kgs HSC3/F/P/150	HSC3/PT11/PT/150 700/650 kgs HSC3/F/PT/150	HSC3/PT11/UHM/150 700/650 kgs HSC3/F/UHM/150	HSC3/PT11/C/150 850/725 kgs HSC3/F/C/150	210 (8 1/4)	75 (3)	150 (6)
HSC3/PT11/P/200 650/500 kgs HSC3/F/P/200	HSC3/PT11/PT/200 675/625 kgs HSC3/F/PT/200	HSC3/PT11/UHM/200 1000/950 kgs HSC3/F/UHM/200	HSC3/PT11/C/200 1250/1100 kgs HSC3/F/C/200	260 (10 1/4)	75 (3)	200 (8)
HSC3/PT11/P/250 650/500 kgs HSC3/F/P/250	HSC3/PT11/PT/250 700/650 kgs HSC3/F/PT/250	HSC3/PT11/UHM/250 1175/1150 kgs HSC3/F/UHM/250	HSC3/PT11/C/250 1300/1150 kgs HSC3/F/P/250	311 (12 1/4)	75 (3)	250 (10)
HSC3/PT11/P/300 650/500 kgs HSC3/F/P/300	HSC3/PT11/PT/300 725/675 kgs HSC3/F/PT/300	HSC3/PT11/UHM/300 1300/1250 kgs HSC3/F/UHM/300	HSC3/PT11/C/300 1350/1200 kgs HSC3/F/C/300	362 (14 1/4)	75 (3)	300 (12)

*RWHZ
100 kg max*

*7.005 Exg
91-15
254*

Note : Tolerance on the wheel diameter 'D' upto & including 100 mm shall be ± 2 mm and for the diameters greater than 100 mm shall be ± 2 percent (%)



HSC/TW SERIES *PARTS: 6 1/4" x 4 1/4" x 12 MM T*

SWIVEL/FIXED CASTORS

4" to 8" DIAMETER & above

Twin wheels give the advantages of a greater load for the same castor height with easier swivelling movement. The load is spread over a wider floor area, but because of the DIFFERENTIAL action of the twin wheels the scrubbing effect that arises from the use of wide tread small diameter single wheels is avoided

The fully enclosed swivel retains the lubricant reducing maintenance to minimum. As with all HSC castors the swivel bearing is also available with a double ball-race for greater ease of movement

The companion rigid brackets matching the swivel are also available or where a rocking formation is preferred can be supplied with a large diameter wheel



Swivel Castors



Rigid Castors

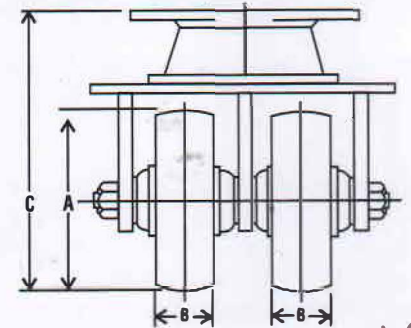
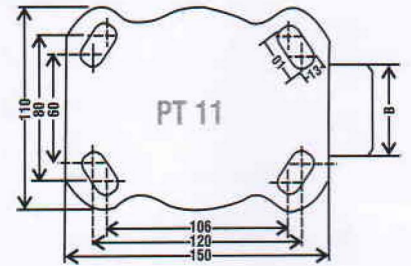

*160 x 160
120.5 x 59
13.5*

HSC 2/PT/RT/100/R/TW - 6.260

Wheel Dia mm (Inches)	Tread Width mm (Inches)	Overall Height mm (Inches)	Load Capacity Kgs.	Type Of Wheel	Catalogue Reference Swivel	Catalogue Reference Rigid Bracket
100 (4)	50 (2)	168 (6 5/8)	450 kg 320 kg	Cast iron roller Bearings Rubber tyred roller Bearings	HSC2/PT/C/100/R/TW HSC2/PT/RT/100/R/TW <i>RAU/102</i>	HSC2/F/C/100/R/TW HSC2/F/RT/100/R/TW
125 (5)	50 (2)	194 (7 5/8)	900 kg 450 kg	Cast iron roller Bearings Rubber tyred roller Bearings	HSC2/PT/C/125/R/TW HSC2/PT/RT/125/R/TW	HSC2/F/C/125/R/TW HSC2/F/RT/125/R/TW
150 (6)	50 (2)	219 (8 5/8)	1350 kg 600 kg <i>750</i>	Cast iron roller Bearings Rubber tyred roller Bearings	HSC2/PT/C/150/R/TW HSC2/PT/RT/150/R/TW	HSC2/F/C/150/R/TW HSC2/F/RT/150/R/TW <i>RAU</i>
200 (8)	50 (2)	270 (10 5/8)	1800 kg 1000 kg	Cast iron roller Bearings Rubber tyred roller Bearings	HSC2/PT/C/200/R/TW HSC2/PT/RT/200/R/TW	HSC2/F/C/200/R/TW HSC2/F/RT/200/R/TW

NOTE:
Also available:
Ball Bearings in the wheel.
Phenorex (fibre) or any other special wheel material.
Wheel diameter above 8".

Note: Tolerance on the wheel diameter 'D' upto & including 100 mm shall be ± 2 mm and for the diameters greater than 100 mm shall be ± 2 percent (%)



HSC/ST SERIES

STEERING ASSEMBLIES SWIVEL CASTORS

ISO 9001-2000
Quality System
Quality Endorsed Company
Certification No: QEC13252

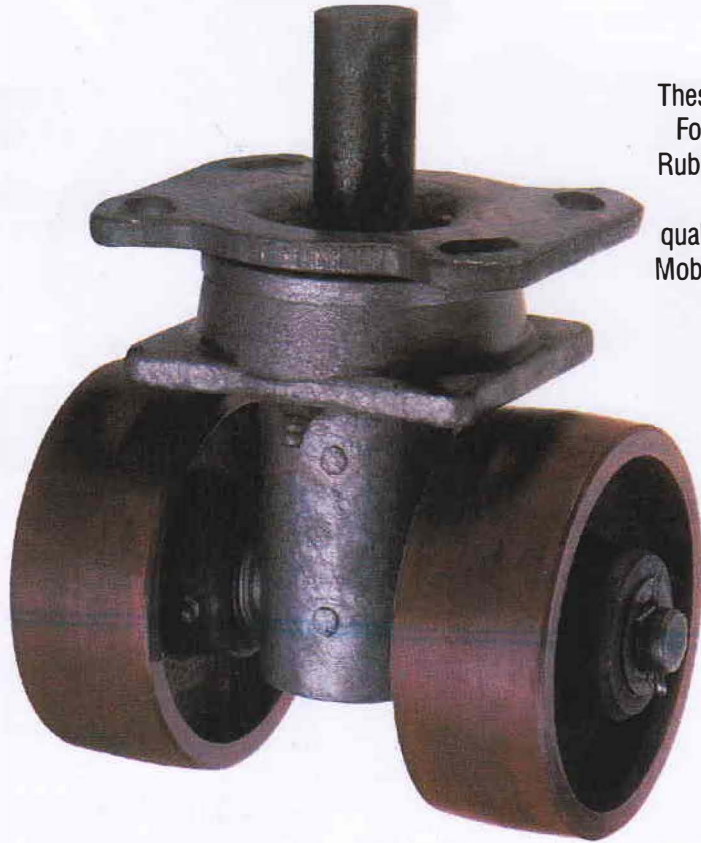

These are pre-fabricated units incorporating the HSC Forged Steel Swivel and fitted with either Cast Iron, Rubber Tyred, Phenorex wheels or any of the wheels shown on page 02. They form a high quality component for Lift trucks, Pallet transporters Mobile conveyors, Warehouse trucks etc, The centre column, for steering arm or tow bar attachment is 1 1/4" dia. & projects 2 1/4" above the fixing plate in the standard model, But these dimensions may be varied to suit individual Requirements,

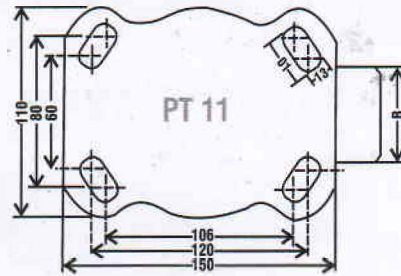
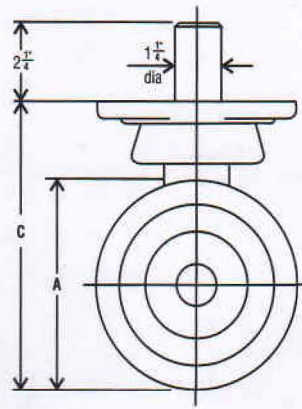
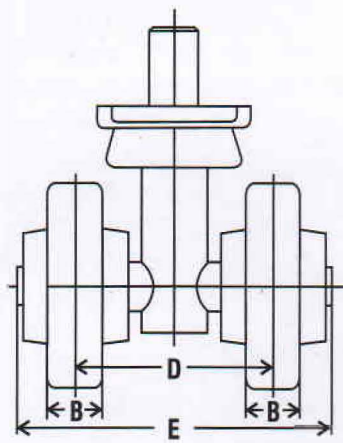

Wheel Dia A mm (Inches)	Tread Width B mm (Inches)	Overall Height C mm (Inches)	Wheel Centres D mm (Inches)	Overall Axle E mm (Inches)	Load Capacity Kgs.	Type Of Wheel	Catalogue Reference
100 (4)	50 (2)	168 (6 5/8)	152 (6)	241 (9 1/2)	400 kg 250 kg	Cast iron roller Bearings Rubber tyred roller Bearings	HSC2/ST/C/100/R/TW HSC2/ST/RT/100/R/TW
125 (5)	50 (2)	194 (7 5/8)	152 (6)	241 (9 1/2)	450 kg 300 kg	Cast iron roller Bearings Rubber tyred roller Bearings	HSC2/ST/C/125/R/TW HSC2/ST/RT/125/R/TW
150 (6)	50 (2)	219 (8 5/8)	152 (6)	241 (9 1/2)	700 kg 400 kg	Cast iron roller Bearings Rubber tyred roller Bearings	HSC2/ST/C/150/R/TW HSC2/ST/RT/150/R/TW
200 (8)	50 (2)	270 (10 5/8)	152 (6)	241 (9 1/2)	700 kg 450 kg	Cast iron roller Bearings Rubber tyred roller Bearings	HSC2/ST/C/200/R/TW HSC2/ST/RT/200/R/TW

NOTE:
Also available:
Ball Bearings in the wheel.
Phenorex (fibre) or any other
special wheel material.
Wheel diameter above 8".

Note : Tolerance on the wheel diameter 'D' upto & including 100 mm shall be ± 2 mm and for the diameters greater than 100 mm shall be ± 2 percent (%)



HSC SERIES

TRACK SWIVEL/FIXRD CASTORS

Track castors reduce labour fatigue, protect floor surfaces and allow increased mobility.

These forged steel track castors are designed for use on 'T' section tracks or inverted angle iron tracks. The castors are HSC series fitted with either square channelled or Vee-grooved wheels. The diagrams below show section through each wheel. Rigid castors (HSC/F) can be supplied fitted with flanged wheels.

The table below gives information on the dimensions of the wheels.

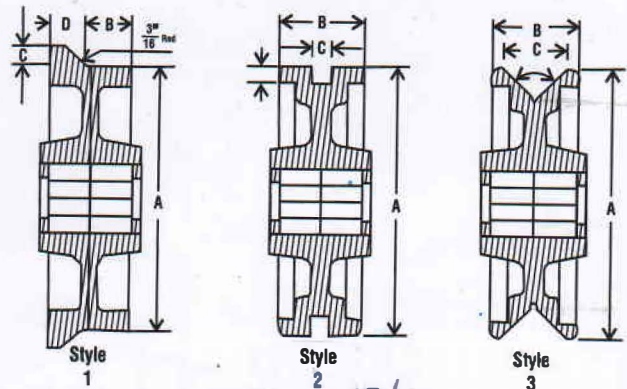

Rigid Bracket dimensions

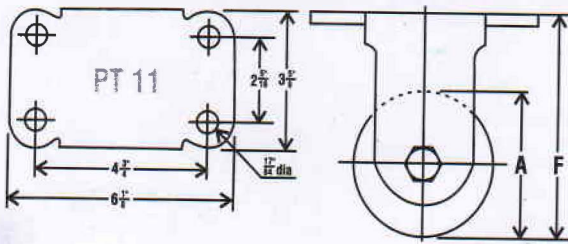

Swivel dimensions

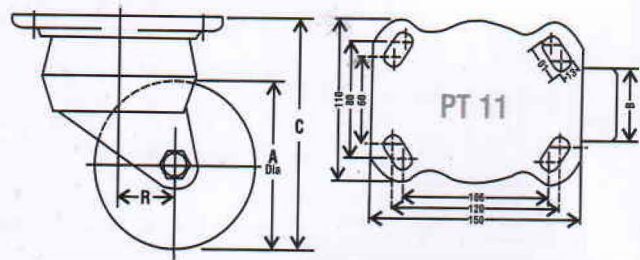

Wheel Dia A mm	Tread Style mm	Tread Width B mm	Flange/Groove/V C mm	Width D mm	Swivel Offset E mm	Overall Height F mm	Load Capacity Kgs.	Wheel Bearing	Catalogue Reference Swivel	Catalogue Reference Fixed	Tread Shape
100	1	33	13	13			300 kg	Roller Bearings	HSC2/PT/C/100/R/S1	HSC2/F/C/100/R/S1	F
100	2	50	20		40	152	300 kg	Roller Bearings	HSC2/PT/C/100/R/S2	HSC2/F/C/100/R/S2	G
100	3	50	25				300 kg	Roller Bearings	HSC2/PT/C/100/R/S3	HSC2/F/C/100/R/S3	V
150	1	35	13		48	203	900 kg	Roller Bearings	HSC2/PT/C/150/R/S1	HSC2/F/C/150/R/S1	F
150	2	50	38	13			900 kg	Roller Bearings	HSC2/PT/C/150/R/S2	HSC2/F/C/150/R/S2	G
150	3	50	32				900 kg	Roller Bearings	HSC2/PT/C/150/R/S3	HSC2/F/C/150/R/S3	V
200	1		32		60	254	900 kg	Roller Bearings	HSC2/PT/C/200/R/S1	HSC2/F/C/200/R/S1	F
200	2	50	13	13			900 kg	Roller Bearings	HSC2/PT/C/200/R/S2	HSC2/F/C/200/R/S2	G
200	3	50	32				900 kg	Roller Bearings	HSC2/PT/C/200/R/S3	HSC2/F/C/200/R/S3	V
250	1		32		70	305	1000 kg	Roller Bearings	HSC2/PT/C/250/R/S1	HSC2/F/C/250/R/S1	F
250	2	50	13	13			1000 kg	Roller Bearings	HSC2/PT/C/250/R/S2	HSC2/F/C/250/R/S2	G
250	3	50	32				1000 kg	Roller Bearings	HSC2/PT/C/250/R/S3	HSC2/F/C/250/R/S3	V

20(13/16)



Note: Dimensions to the wheel flange 'D' type 3 technology 135 mm max dia. 2 mm and for the diameter greater than 100 mm max dia. 2 mm (0.075").

HSC/TT SERIES

CUSTOM BUILT CASTORS

ISO 9001-2000
Quality System
Quality Endorsed Company
Certification No: DEC13252

Forged Steel HSC series castors with 14" & 16" dia. Wheels

The large diameter wheel offer the greatest ease of movement & maximum protection to both load & floor.

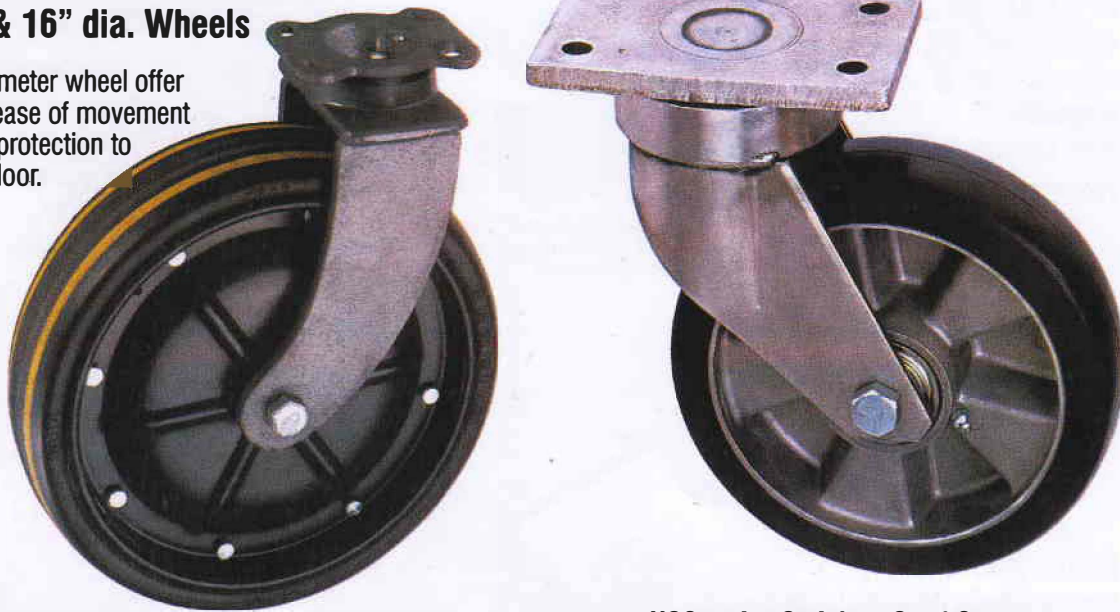

SPRUNG CASTORS:-

Protect Loads, equipment and floors by shocks and vibration.

This design is fitted with disc springs giving a comprehensive standard range of loadings to cover all normal requirements.

The spring stacks are fitted with stops to guard against accidental overloading.



HSC series Stainless Steel Castors are the requirement of the day by environment conscious Industries for heavy duty usage. These castors have the unique 'Rexello' side race swivel construction, and are fitted with wheels of either Nylon, UHM or Polyurethane on Heavy Duty Aluminium Blanks.

HSC series castors fitted with a wheel lock & a 4 station directional lock



HSC SERIES

ACCESSORIES



Quality Endorsed Company Certification No. DEC13252

FOR ROTATING OR OSCILLATING APPLICATIONS:-

Chain or belt conveyors, turn tables, index tables etc. Manufacturers of a wide variety of factory equipments frequently use REXELLO unbreakable ball bearing or Taper roller bearing swivels as extra large thrust or radial bearings. HSC Swivel unit Load capacity - 1800 kgs.



FLOOR TRUCK LOCK SERIES

EXCELLENT FOR PLATFORM TRUCK & ALTERNATIVE TO BRAKE

Features :

Special Rexello Floor truck lock secures platform truck loading and unloading. All you have to do is step down on the lock to engage and step down again to disengage. May be bolted or welded to platform truck.

Lock foot :

Bottom of lock is rubber padded to prevent damage to floors and maximize grip.

Finish :

Corrosion resistant bright zinc finish.



Heavy Duty

L.C. 3000 kg Excl.



Light / Medium Duty

L.C. 250 kg Excl.

ALTERNATIVE AVAILABLE PLATES IN HSC SERIES

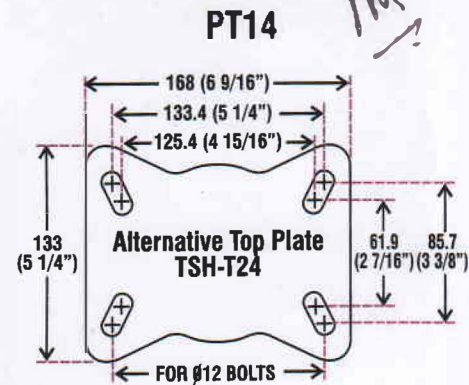
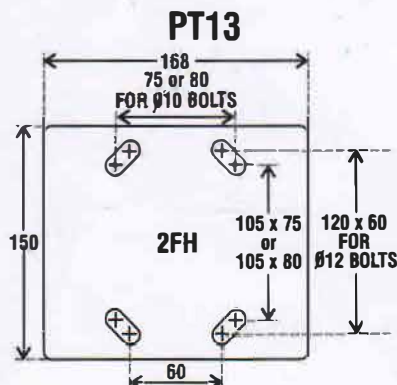
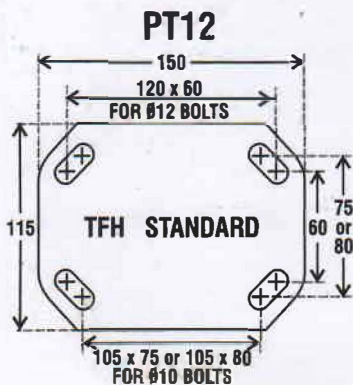

For Swivel & Fixed Castors PT11 Plate is the Standard Plate.



HSC/TT SERIES

CUSTOM BUILT
PLAT TRUCKS

WHEEL ASSEMBLY

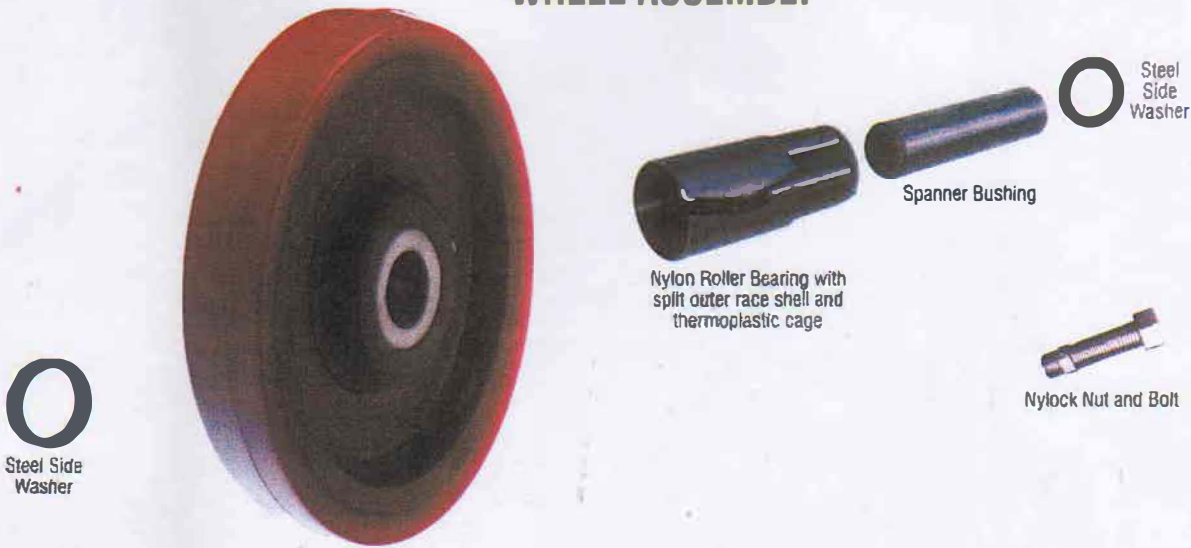

Rexello has standardised platform trucks with appropriate Rexello Castor Wheels, to suit all your needs on work floors. Available in Single / Double Push Handles.



They are with heavy duty tubular one side push handle, both sides push handles and folding push handles.

ALTERNATIVE AVAILABLE PLATES IN HSC SERIES

PT15

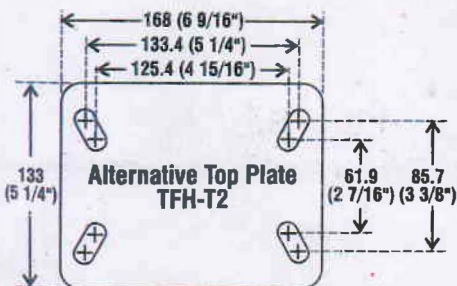

PT16

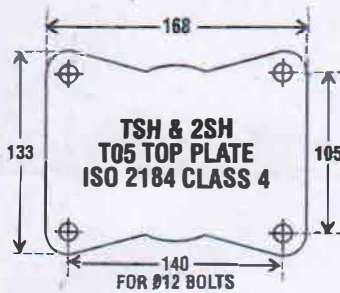

PT17

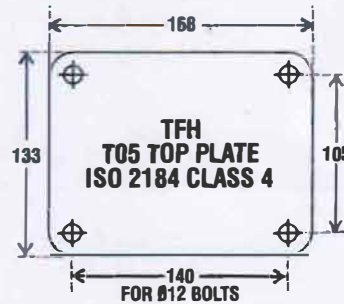

ISO 9001-2000
Quality System
Quality Endorsed Company
Certification No. QEC 13252

